

# Next Dimension Signature Series

## CASEMENT

SECTION DETAILS: OPERATING / PICTURE

SCALE: 3" = 1'-0"

OPERATING

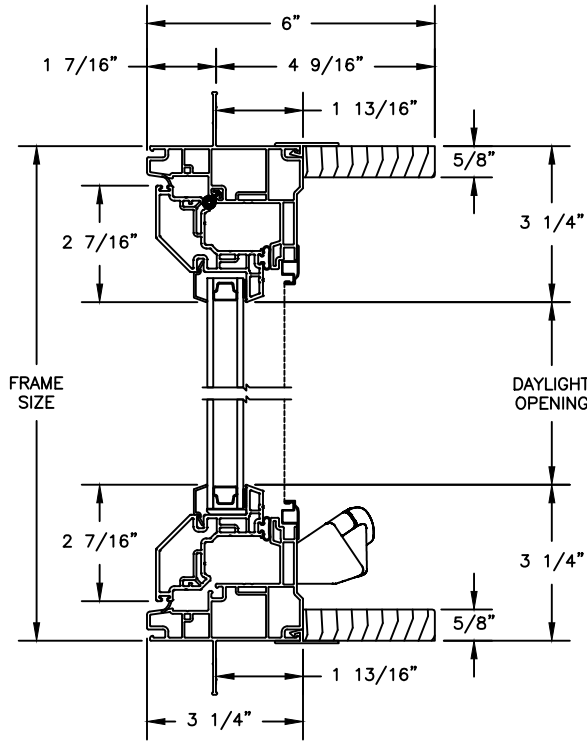

HEAD JAMB & SILL

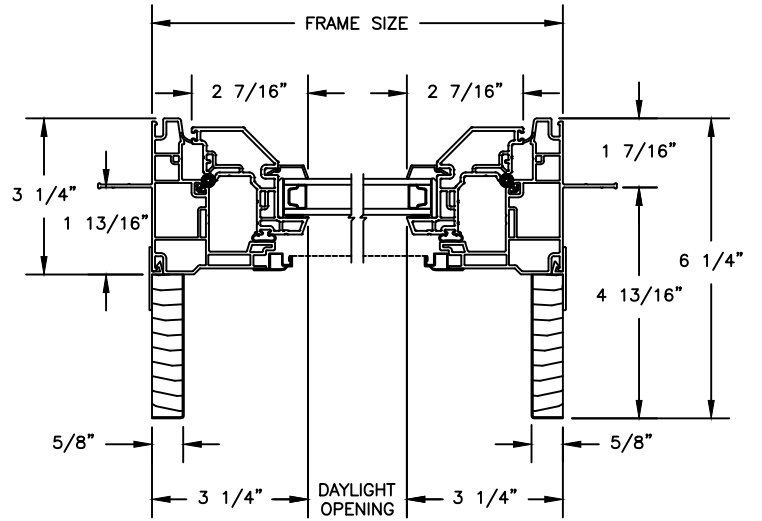

JAMBS

PICTURE

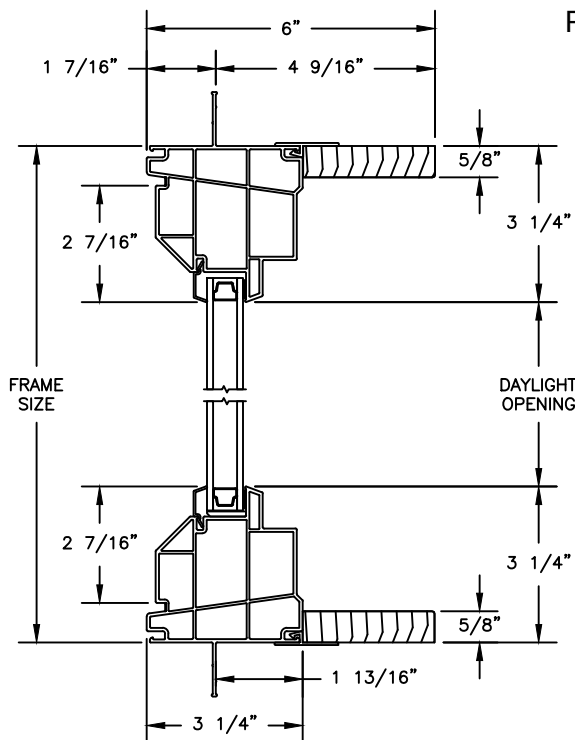

HEAD JAMB & SILL

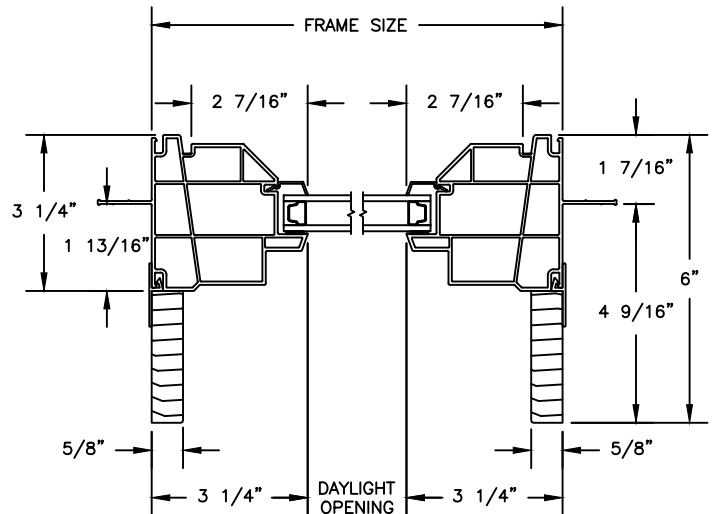

JAMBS

# Next Dimension Signature Series

## CASEMENT

SECTION DETAILS: OPERATING / PICTURE 4 916" JAMB

SCALE: 3" = 1'-0"

### OPERATING

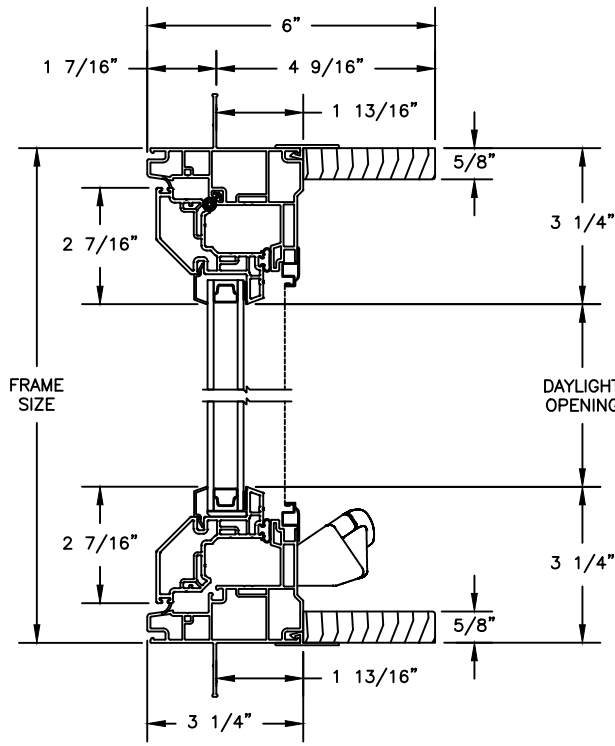

HEAD JAMB & SILL

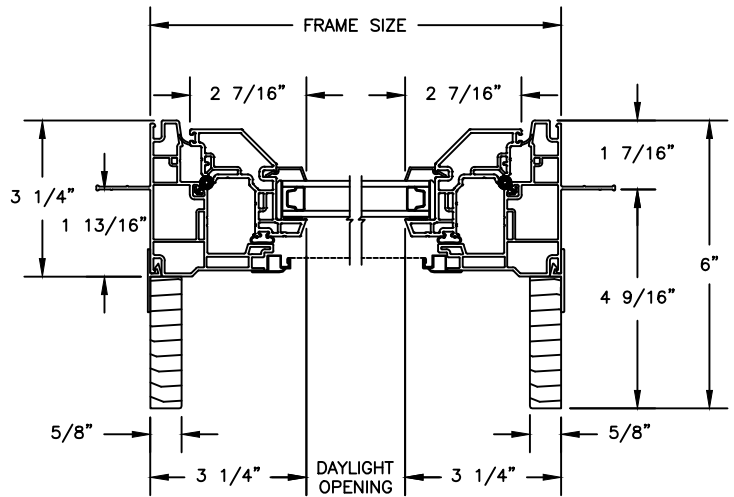

JAMBS

### PICTURE

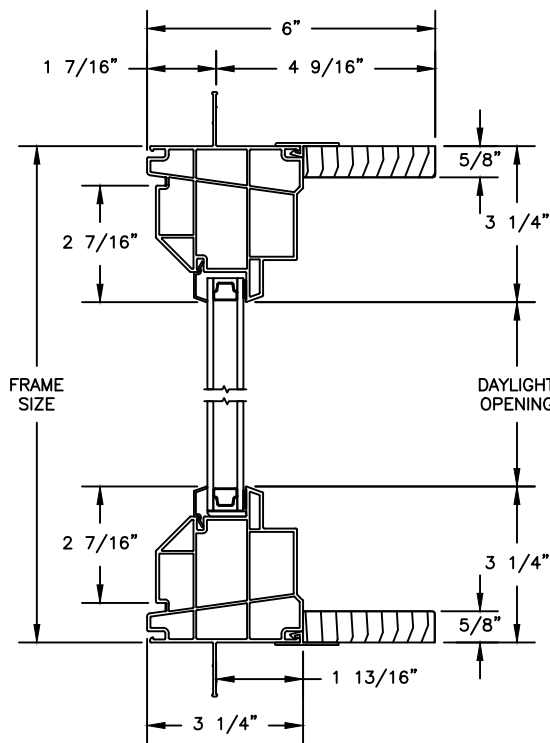

HEAD JAMB & SILL

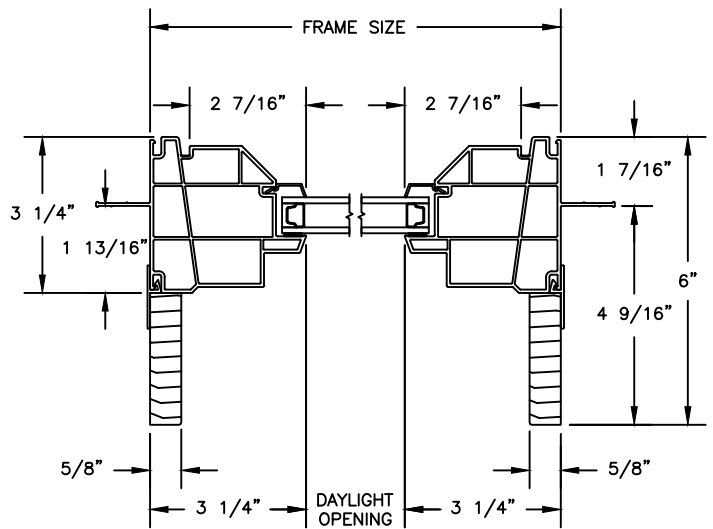

JAMBS

# Next Dimension Signature Series

## CASEMENT

SECTION DETAILS: MULLIONS

SCALE: 3" = 1'-0"

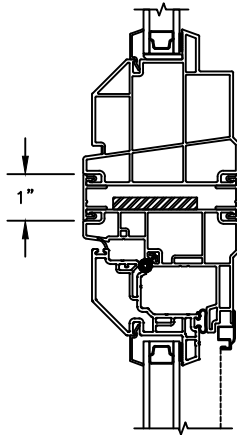

HORIZONTAL MULLION  
PICTURE/OPERATOR

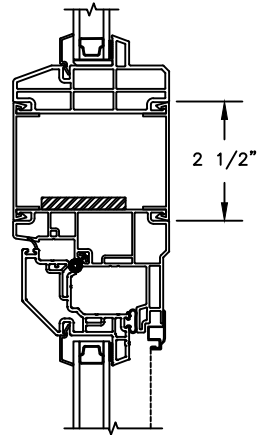

HORIZONTAL 2" MULLION  
RADIUS/OPERATOR

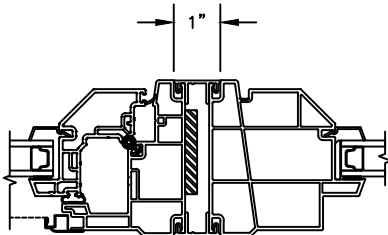

VERTICAL MULLION  
OPERATOR/PICTURE

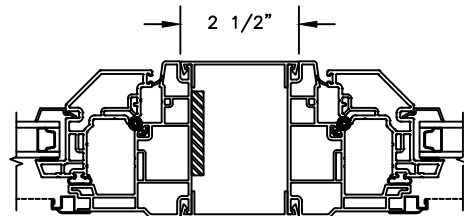

VERTICAL 2" MULLION  
OPERATOR/OPERATOR

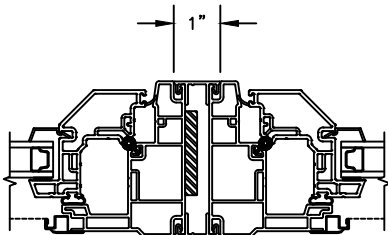

VERTICAL MULLION  
OPERATOR/OPERATOR

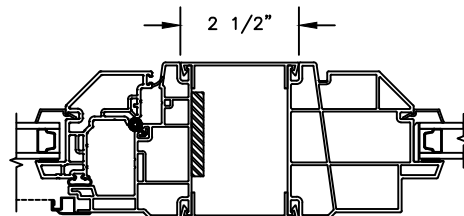

VERTICAL 2" MULLION  
OPERATOR/PICTURE

# Next Dimension Signature Series

## CASEMENT

SECTION DETAILS : DIVIDED LITE OPTIONS

SCALE: 3" = 1'-0"

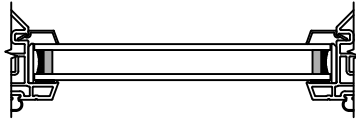

INSULATING GLASS

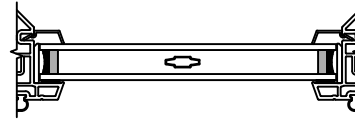

3/4" PROFILED INNERGRILLE

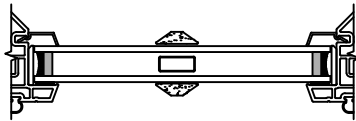

7/8" PUTTY WDL  
WITH INNERBAR

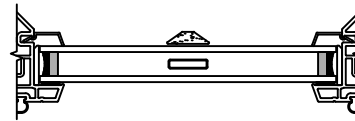

7/8" PUTTY WDL (EXTERIOR ONLY)  
WITH 13/16" FLAT INNERGRILLE

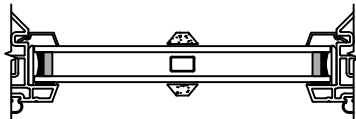

5/8" PUTTY WDL  
WITH INNERBAR

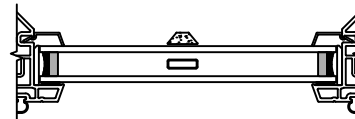

5/8" PUTTY WDL (EXTERIOR ONLY)  
WITH 5/8" FLAT INNERGRILLE

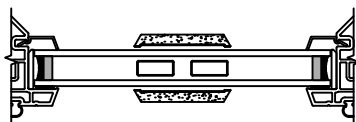

2" PUTTY WDL  
WITH INNERBAR

# Next Dimension Signature Series

## CASEMENT

SECTION DETAILS: BRICKMOULD ACCESSORY

SCALE: 3" = 1'-0"

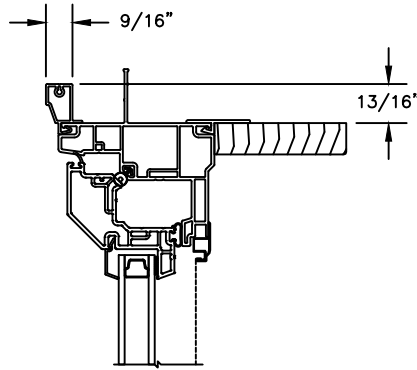

HEAD JAMB WITH  
BRICKMOULD ACCESSORY

# Next Dimension Signature Series

## CASEMENT

SECTION DETAILS : CONSTRUCTION

SCALE: 2" = 1'-0"

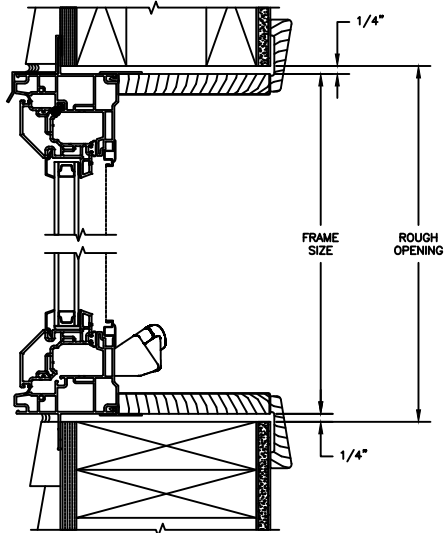

HEAD JAMB & SILL  
2 X 6 FRAME WITH SIDING

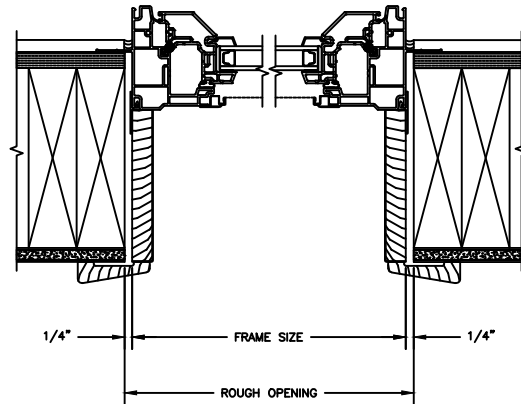

JAMBS  
2 X 6 FRAME WITH SIDING

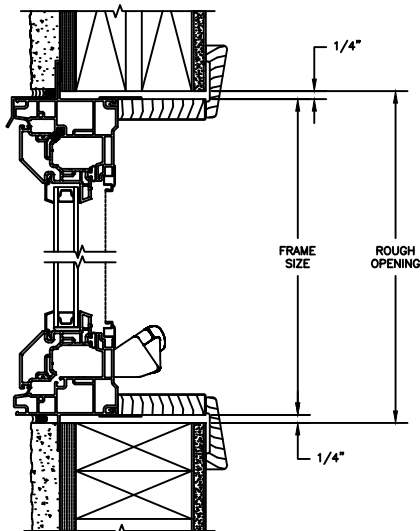

HEAD JAMB & SILL  
2 X 4 FRAME WITH STUCCO

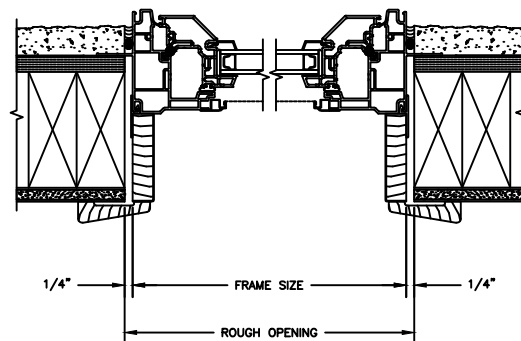

JAMBS  
2 X 4 FRAME WITH STUCCO

NOTE:  
THE ABOVE WALL SECTIONS REPRESENT TYPICAL WALL CONDITIONS, THESE DETAILS ARE NOT INTENDED AS INSTALLATION INSTRUCTIONS. PLEASE REFER TO THE INSTALLATION INSTRUCTIONS PROVIDED WITH THE PURCHASED UNITS.

# Next Dimension Signature Series

## CASEMENT

SECTION DETAILS : CONSTRUCTION

SCALE: 2" = 1'-0"

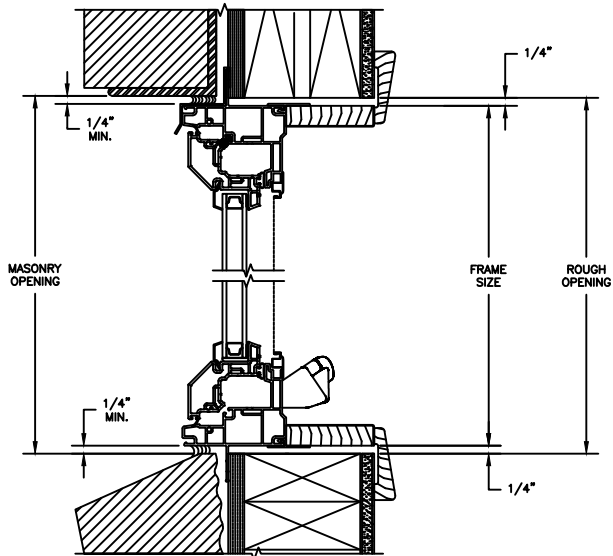

HEAD JAMB & SILL  
2 X 4 FRAME WITH BRICK VENEER

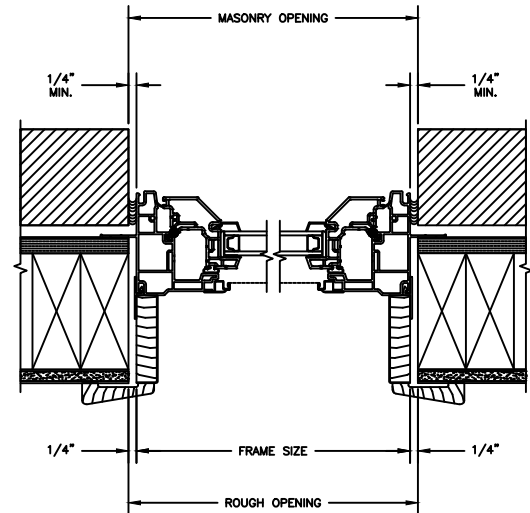

JAMBS  
2 X 4 FRAME WITH BRICK VENEER

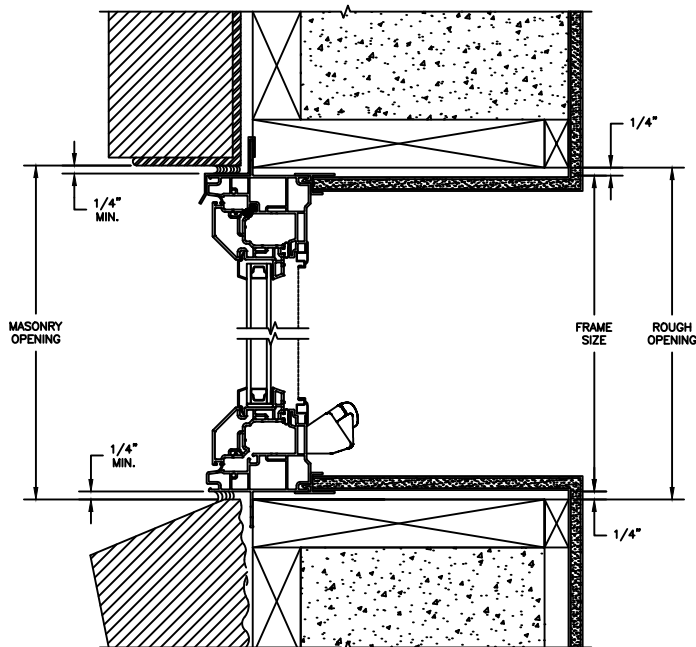

HEAD JAMB & SILL  
8" CONCRETE BLOCK WALL  
WITH BRICK VENEER

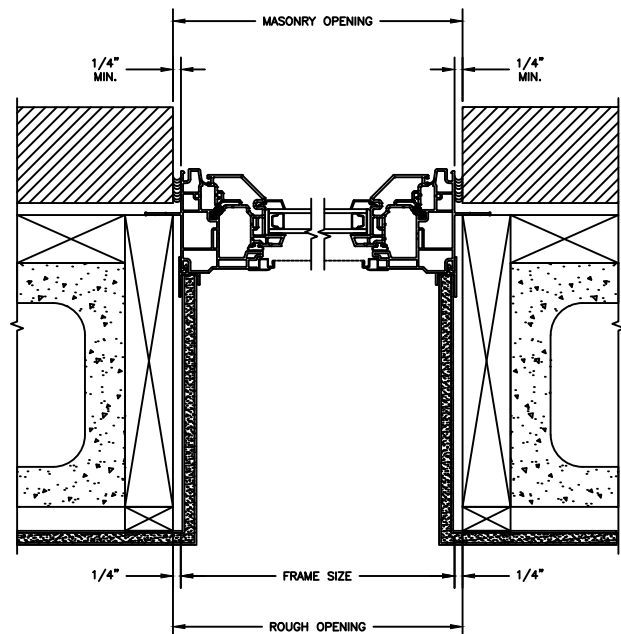

JAMBS  
8" CONCRETE BLOCK WALL  
WITH BRICK VENEER

NOTE:  
THE ABOVE WALL SECTIONS REPRESENT TYPICAL WALL CONDITIONS, THESE DETAILS ARE NOT INTENDED AS INSTALLATIONS INSTRUCTIONS. PLEASE REFER TO THE INSTALLATION INSTRUCTIONS PROVIDED WITH THE PURCHASED UNITS.

# Next Dimension Signature Series

## CASEMENT

SECTION DETAILS : 30/45 DEGREE ANGLE BAY HORIZONTAL SECTIONS

SCALE: 3" = 1'-0"

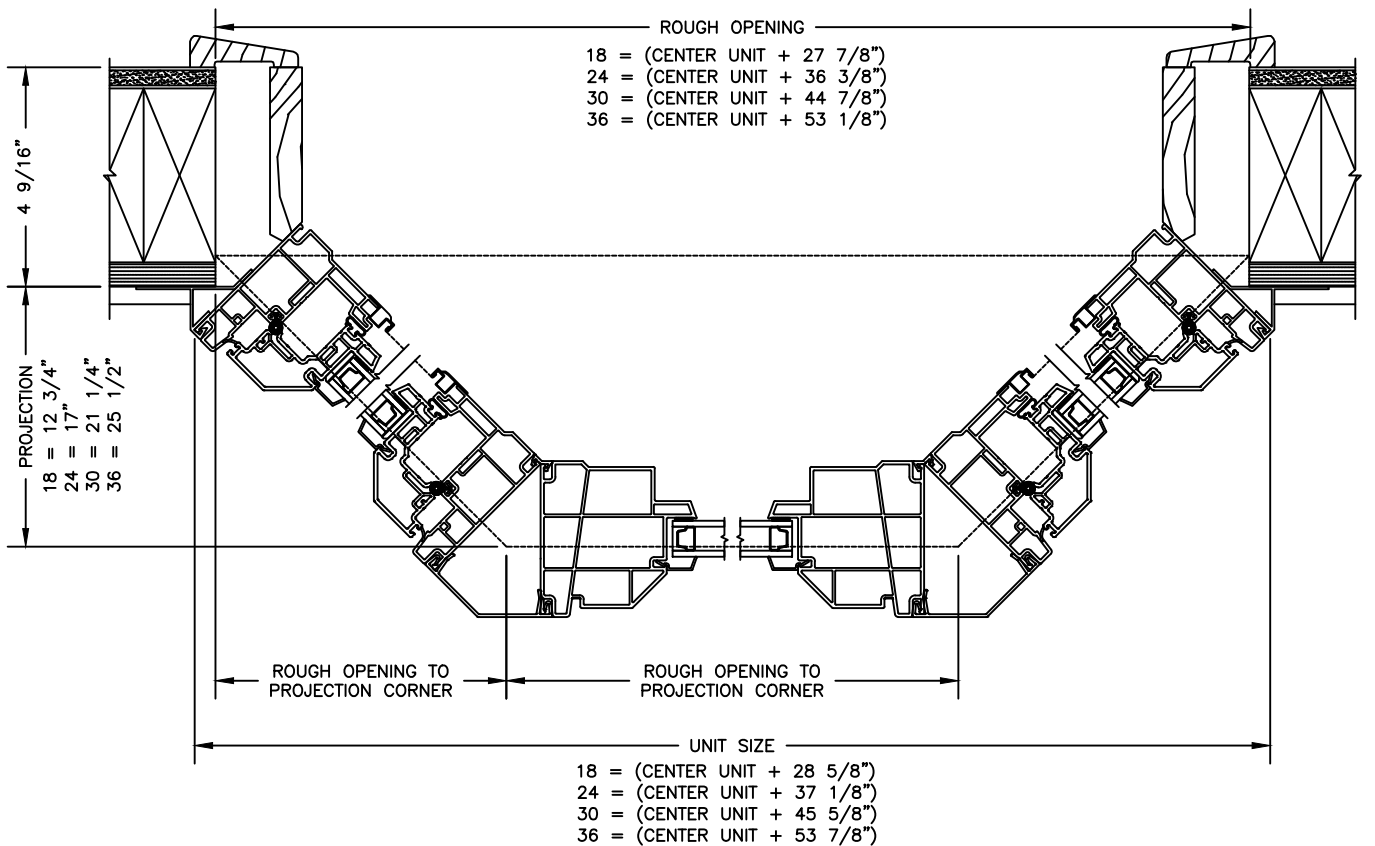
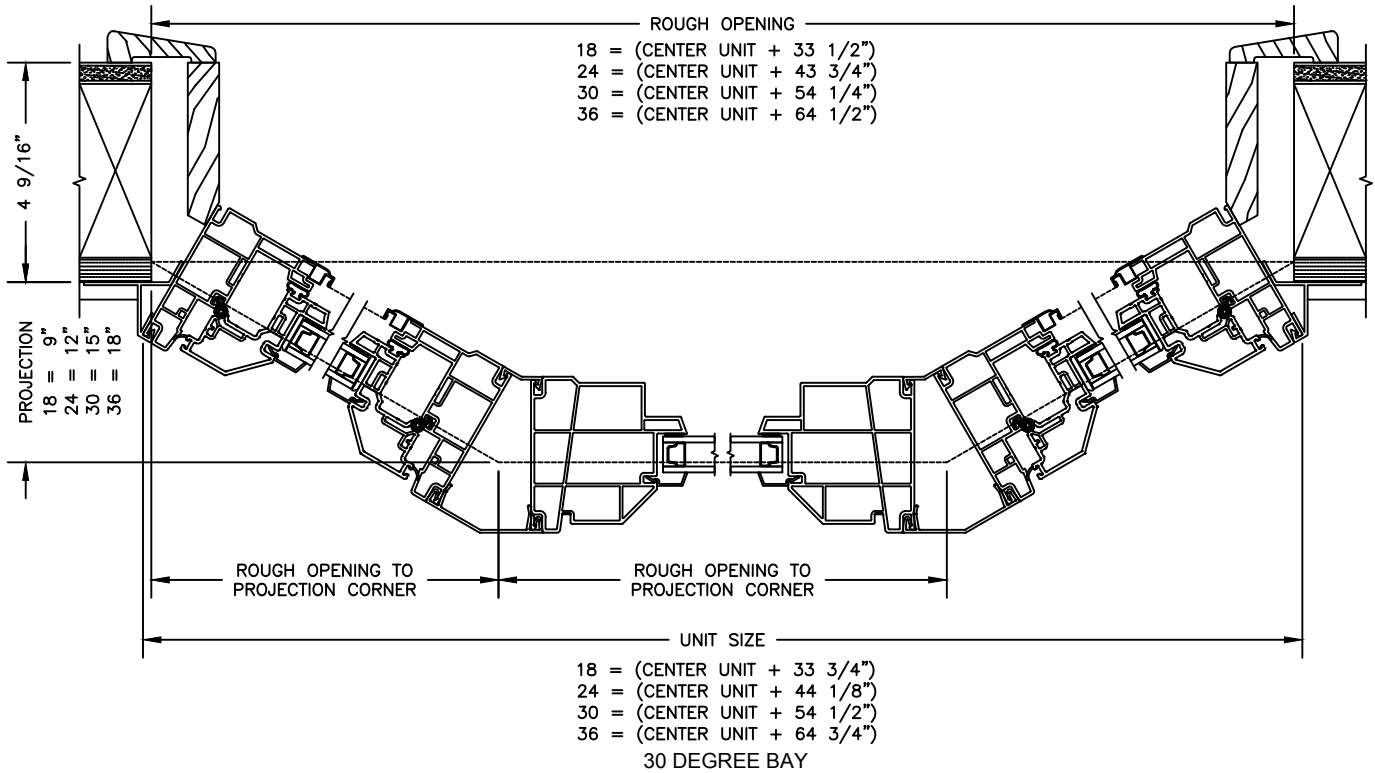



# Next Dimension Signature Series

## CASEMENT BOW / BAY

SECTION DETAILS : BOW / BAY

SCALE: 3"=1'-0"

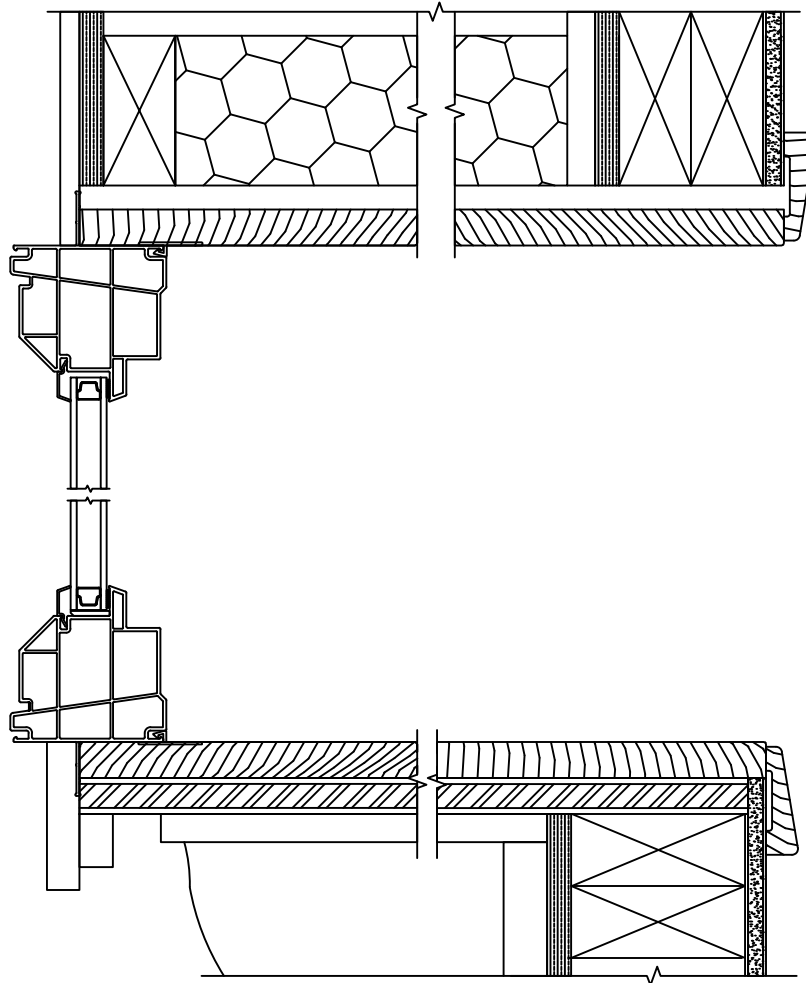

### NOTES:

Standard set-up unit has hardware, weatherstrip, drip cap, screens, and head and seat boards applied. Standard jamb with extender is 4 9/16". Head and seat boards are select pine, edge-glued, finger-jointed and sanded, 1" finished thickness. Optional 3/4" veneered head and seat boards are available in clear pine and oak.

Rough and masonry opening heights include head and seat boards. If head and seat boards are not specified, subtract 3/4" for each board. Construction materials supplied by others.

\* Projection is defined as the dimension from the back of the nailing flange to the exterior of the wall sheathing.

Height Measurements			
BAY		BOW	
Height	R.O. Height	Height	R.O. Height
42	3-8	48	4-1 1/2
48	4-2	54	4-7 1/2
54	4-8	60	5-1 1/2
66	5-8	66	5-7 1/2
		72	6-1 1/2

### NOTES:

Bay units must be configured from standard size units. An almost infinite number of combinations are possible from a wide range of standard units available. Add together casement windows of the same height to create any grouping desired.

# Next Dimension Signature Series

## CASEMENT BOW

SECTION DETAILS : BOW

SCALE: 2" = 1'-0"

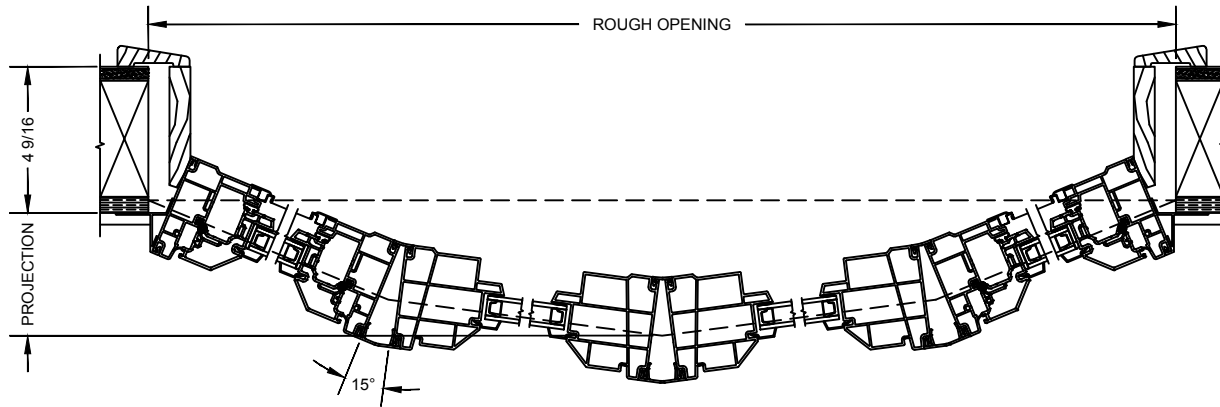

4 WIDE BOW

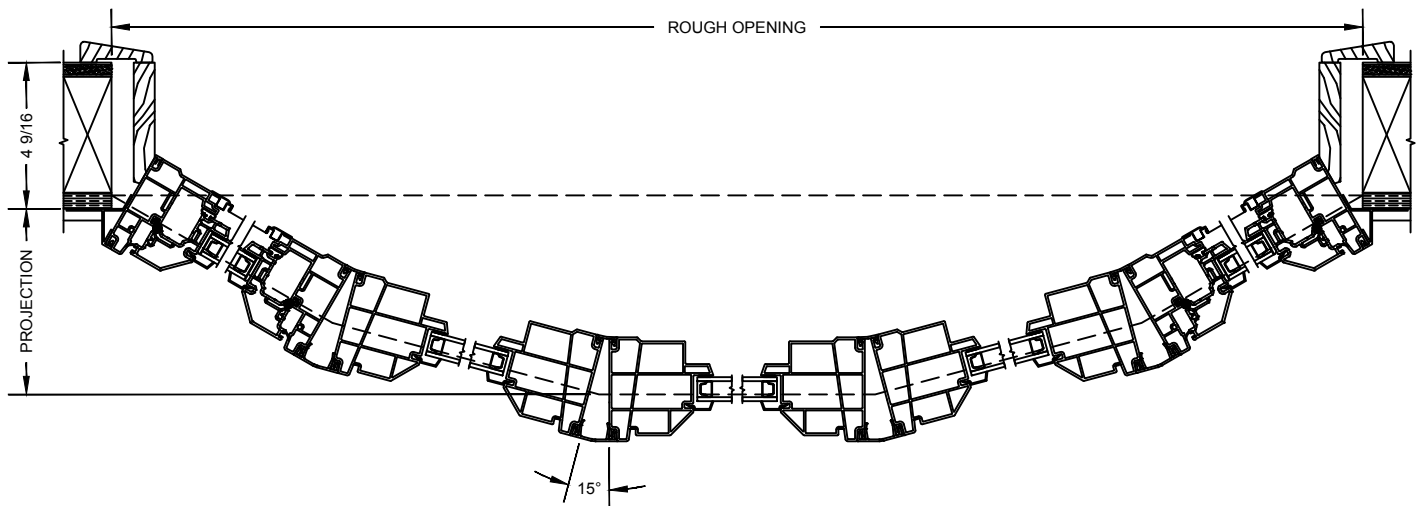

5 WIDE BOW

**OPTIONS:**

Bow units must be configured from standard size units. An almost infinite number of combinations are possible from the wide range of casement heights available.

Width Measurements			
4-WIDE			
Width	Unit Width	R.O. Width	Projection
18	5-9 3/4	5-9 1/2	9-0 1/16
24	7-8 3/4	7-8 1/2	1-0 1/8
30	9-7 3/4	9-7 1/2	1-3 3/16
5-WIDE			
18	7-1 1/4	7-0 3/4	1-1 1/2
24	9-5	9-4 1/2	1-6
30	N/A	N/A	N/A