

Pinnacle Clad Spread mull Installation

<u>Parts Needed</u>	<u>Tools Needed</u>	<u>Materials Needed</u>
<ul style="list-style-type: none"> • LVL Spread Mull Material • PVC Material • Exterior Mull Cover • End Cap & Drip Cap • Interior Mull Cover • Nail Fin 	<ul style="list-style-type: none"> • Hammer • UHMW/Wooden Block • Tape Measure & Saw • Chisel • Clamp • Power Drill & 1/8" Drill bit • Silicone, Nail, and Staple Gun 	<ul style="list-style-type: none"> • 100% Silicone • Tremco Chem X Pro • Corrugated Staples (1/2") • 2" Nails • Gusset Plate • 1/2", 16 gauge staples

Spread Mull Construction

- A. Cut Mull Material to length of mull.
- B. Apply 3/16" bead of Chem X Pro between mulling material and the unit (figure 1).
Butter out the Chem X Pro.
- C. Clamp the mull material together
- D. Apply corrugated staples 3" from ends of mull and 6"- 8" spaced down the length of the mull, securing the mull material to the unit (figure 1).

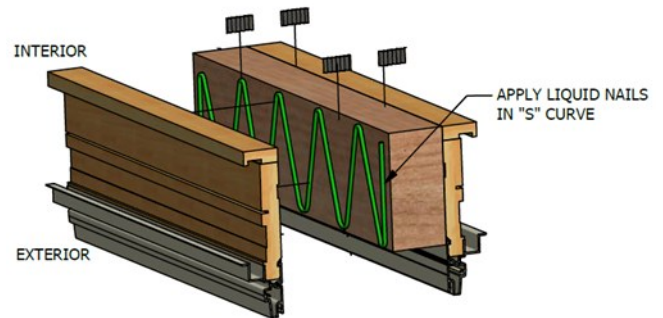

Figure 1

- E. Turn the unit over clad side up and cut PVC material, **(Frame Dimension—1/4")** for drip cap leg clearance. (3 1/4" pinnacle gets no PVC)
 - F. Insert PVC material into channel, then secure with 2" nails, 3" from ends of mull and 6"- 8" spaced down the length of the mull securing PVC material (figure 2).
- Leave room for nail fin and drip cap.

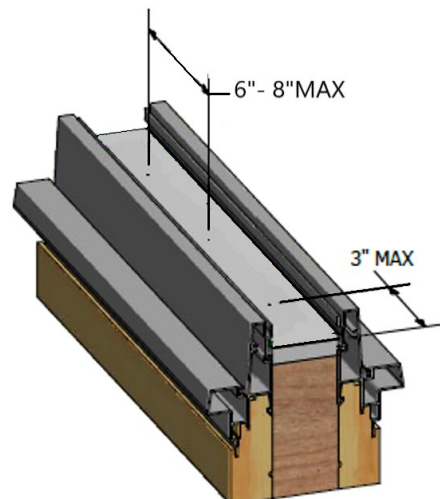
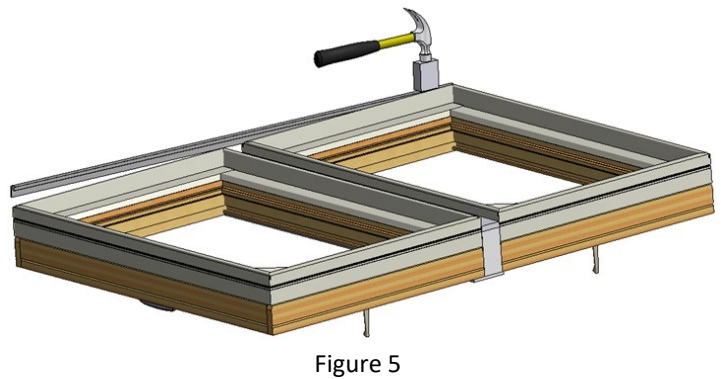
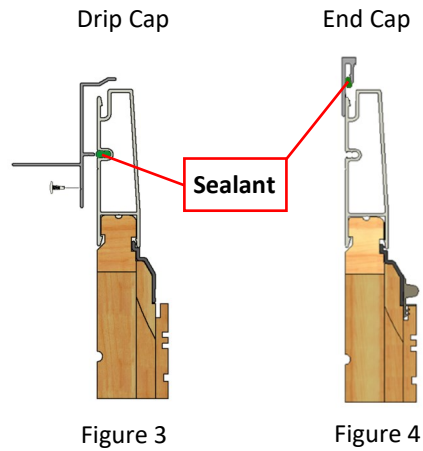

Figure 2

Spread Mull Construction

- G. Measure and cut end caps and drip caps to length.
- End caps cut to length of mullled units
 - Always straight cut drip caps to head length
- H. Using a chisel, notch out metal for a continuous vertical mull cover
- I. Apply at least a 3/16" bead of silicone to the inside groove of the end cap (figure 4), then immediately insert the end cap into the accessory groove using a hammer and UHMW/ wooden block.
- J. Apply at least a 3/16" bead of silicone along nail fin groove (figure 3), then immediately insert the nail fin into the groove and fasten



- K. After the drip cap and end cap are applied, apply a continuous 3/16" bead of silicone around the perimeter of the spread mull cavity (figure 6).

-Tool in silicone while still wet.

- L. Tool in silicone to 3 and 4 way intersections for standard and spread mulls.

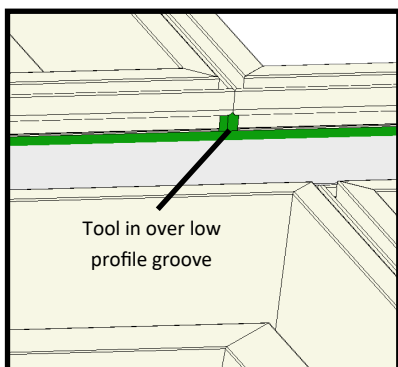
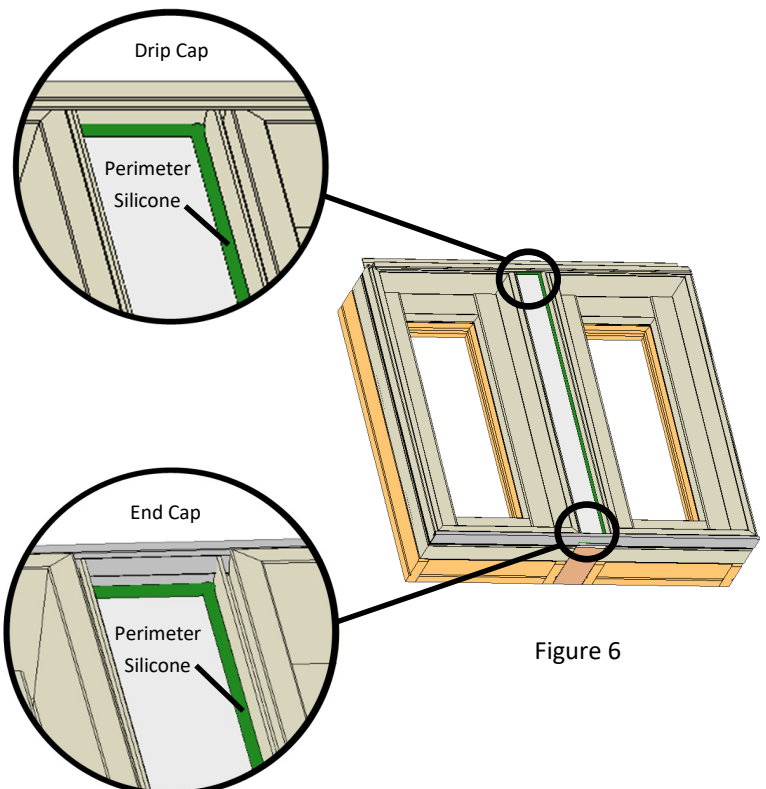

Spread Mull Construction

- M. Cut spread mull cover to length.
- N. Apply 3/16" silicone to mull covers inside legs (figure 8).
- O. Using a hammer and UHMW/wooden block, hammer the mull cover flush with the frame

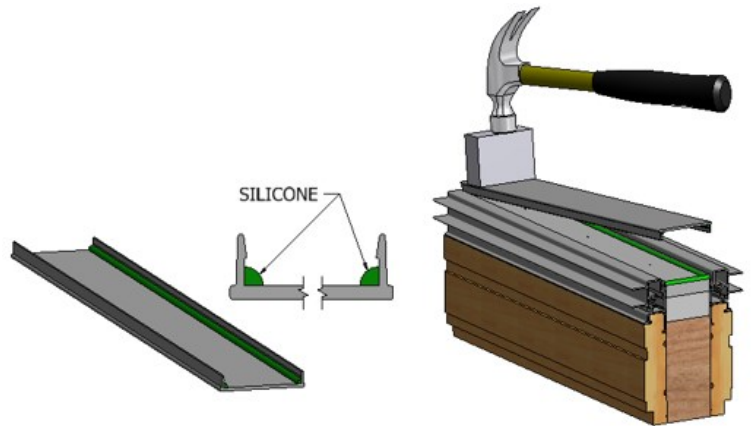

Figure 8

- P. Drill a 1/8" weep hole in the center where end caps on the sill meet spread mulls (figure 9).

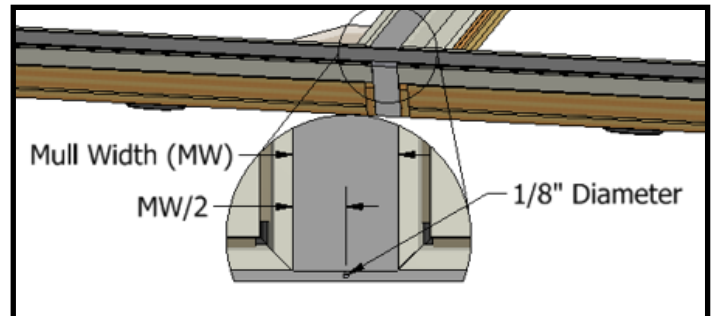

Figure 9

- Q. Verify interior mull cover width and length and cut size.
- R. Nail interior mull cover with finishing nails, 3" from end and 6"-8" spaced down the mull (figure 10).
- I. Apply gusset plates to mull joints using two 1/2", 16 gauge staples per side (figure 5).
- none on DH & door sills.
 - may need to be removed later if subsill is applied.

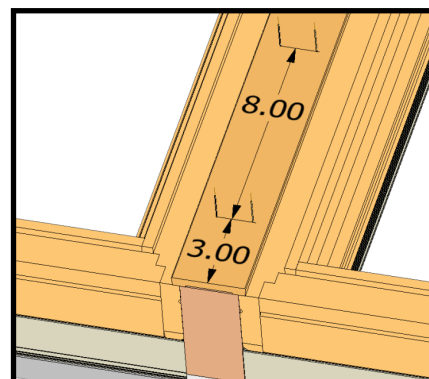

Figure 10



Figure 11