

Installation Guidelines

FOR BI-FOLD DOORS

In-swing / Out-swing / Sliding Patio Door

Installer

- Read instructions completely before attempting installation. Failure to follow these guidelines will forfeit all warranties (written or implied). Windsor Windows & Doors will not be held responsible for any claims or damages resulting from installation.
- Always provide a copy of these instructions to the homeowner.
- Contact your architect or construction professional for installation into other building designs or construction methods.
- Structural support of the sill is required to support the entire sill width, and depth of the sill's interior edge, to the exterior nose of the sill extrusion. If the architect's details do not include this type of structural support, a structural support must be installed and flashed.
- Regional codes and environmental conditions may require installation that is different from these guidelines. It is your responsibility to ensure that local codes and ordinances are followed.

Warning!

- ⚠ **Work Safe!** Always wear proper eye and hearing protection when installing or adjusting Windsor products.
- ⚠ **Use Power Tools Properly!** To avoid personal injury, always follow manufacturers' instructions for safe operation of power tools.
- ⚠ **Ladder Safety!** Working at elevated levels can be hazardous. Always use ladders and scaffolding properly. Consult manufacturers' guidelines for safe use of these types of equipment.

Important

- Windsor reserves the right to change the information contained in these guidelines without notice.
- Maintain a minimum of 1/4" between the door frame and any trim, siding or masonry.
- Use of Windsor products in barrier EIFS systems (synthetic stucco) is not recommended. To do so will forfeit all warranties (written or implied). Windsor Windows & Doors will not be held responsible for any claims or damages resulting from water infiltration.
- Steel fasteners will corrode when used with ACQ pressure treated lumber. Use corrosion resistant fasteners (such as stainless steel) when installing windows in or around these types of materials.
- Door nailing flanges and drip caps (integral or applied) do not take the place of door flashing. All windows and doors must be properly flashed and sealed around the perimeter.

Handling and Storage

- Always carry door panels upright. Do not carry flat! Doing so could result in damage to the panels.
- Do not store units outside.



www.windsorwindows.com

Tools Needed

- Safety Glasses
- Utility Knife
- Hammer (or nail gun)
- Caulk Gun
- Level
- Ladder / Scaffolding
- Square
- Tape Measure
- Drill / Screwdriver

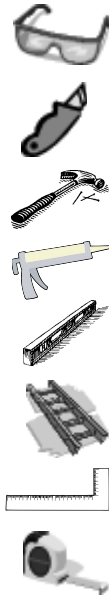

Materials Needed

- Backer Rod
 - 1/4"-1/2" diameter closed cell foam
- Insulation
 - Minimally expanding low pressure polyurethane window and door foam
- Shims
 - Made of cedar or synthetic material
- Coated Deck Screws
 - 1-1/2" x #8
- Silicone Sealant
 - 100% Silicone
- Flashing
 - Self-adhesive flexible flashing that complies with ASTM-D779
- White Petroleum Jelly (Vaseline)
- Roofing Nails
 - 2" galvanized (16D)

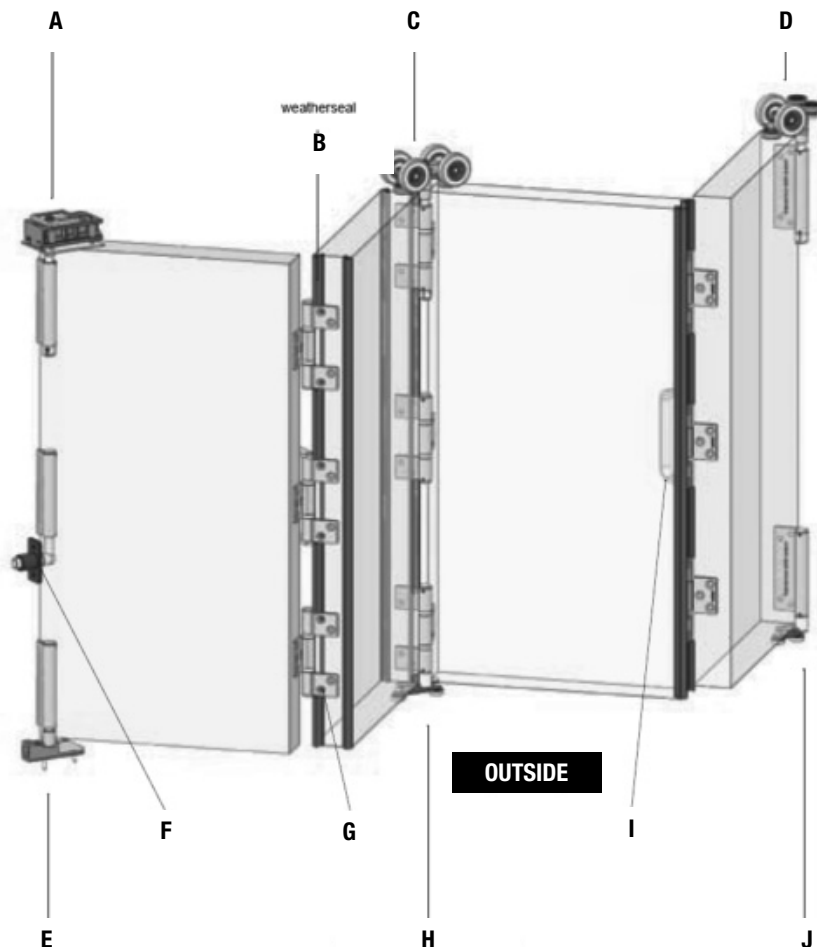

FIG. 1

Bi-fold Door Hardware

- A) Top pivot
- B) Weatherseal
- C) Intermediate carrier
- D) End carrier
- E) Concealed bottom pivot
- F) Wall pivot
- G) Hinge
- H) Concealed intermediate guide
- I) Hinge with handle
- J) Concealed end guide

Step 1: Confirm Structural Integrity

A bi-fold door has different requirements for installation and rough opening preparation than other door systems. The panels in a folding door are top hung, which means the structural header above the door must support the weight of the door. In addition, other applied loads, such as live loads and snow, load must not cause the header to deflect to the point where it interferes with the door operations. The maximum deflection from live loads shall not exceed 1/8" at mid span. If there is uncertainty about the stiffness of the structural header, please consult a licensed structural engineer.

Step 2: Inspect Unit

Before Installation:

- A) Remove all shipping packaging material (blocks, pads, protectors, stretch wrap).
- B) Inspect unit for any damage or defects.
- C) Check all parts received against the packing list to ensure all required parts are present. (Fig. 1)
- D) Contact the nearest Windsor distributor if there are any problem.

Step 3: Prepare Rough Opening

- A) Measure and verify the size of the rough opening. The rough opening should be 1/2" larger than the frame in both width and height.
- B) Verify the rough opening is plumb, level and square. (Fig. 2)
- C) Take diagonal measurements to check for square. (Fig. 2)
- D) Make sure the bottom sill area of the opening does not slope toward the interior.
- E) Make sure that the sill area is straight and level over its length.
- F) Join multiple (horizontal) layers in the header with screws or other fasteners that are resistant to pull-out.
- G) Cut the weather-resistant barrier (WRB) in a "Modified I" pattern. (Fig. 3)
- H) Fold back the WRB on the sides and sill toward the interior and staple into place.
- I) From the exterior, cut the top of the WRB to form a flap. (Fig. 3)
- J) Temporarily tape this top flap up. (Fig. 4)

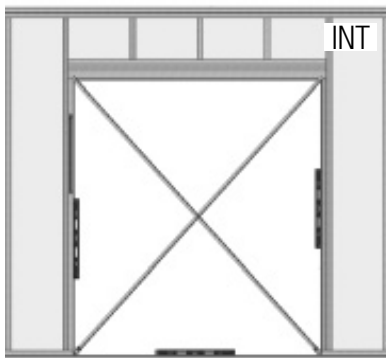

FIG. 2

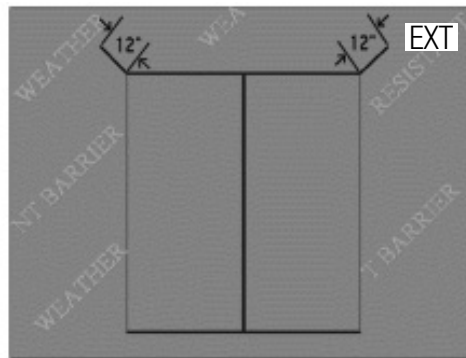

FIG. 3

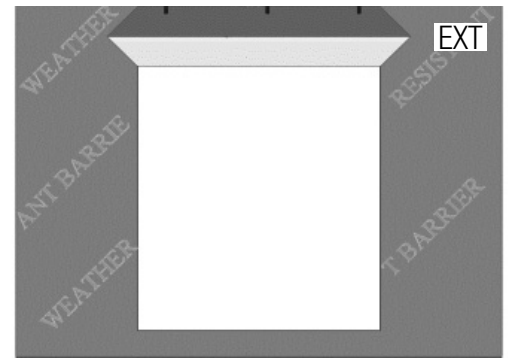

FIG. 4

Step 4: Flashing the Subfloor

- A) **IMPORTANT!**
 - a. Use flashing that is 6" minimum in width.
 - b. Flashing must meet ASTM-D performance requirements.
 - c. Adhesive or mechanically fastened flashing may be used.

- B) Measure the width of the rough opening. Cut a length of flashing that is 12" wider than the rough opening. This will allow you to run the flashing 6" up each side. (Fig. 5)
- C) Cut 1-1/2" slits at each end of the flashing. (Fig. 5)
- D) Apply sill flashing to the rough opening. (Fig. 6)
- E) If you are using non-adhesive flashing:
 - a. Staple flashing into place.
 - b. Seal corner notches using 100% silicone sealant.
- F) Flashing tape must cover the entire sill plate. If needed, apply an additional flashing piece over the first one (start from the exterior and work toward the interior). Maintain a minimum 1" overlap. (Fig. 7)
- G) Apply two continuous, straight beads of 100% silicone sealant to the subfloor to seal the sill to the subfloor. (Fig. 8 & 9)

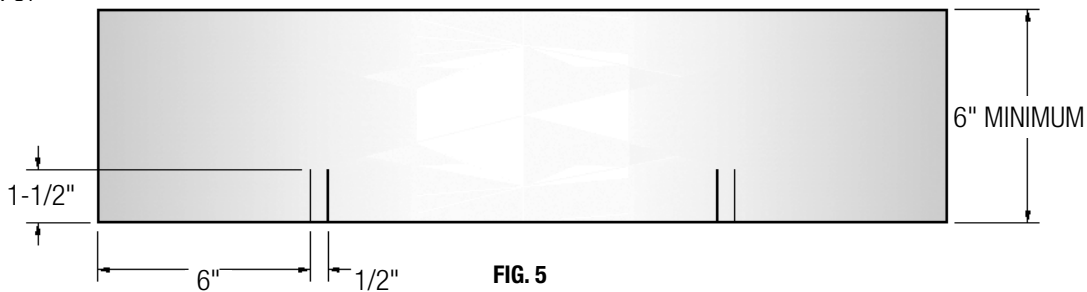

FIG. 5

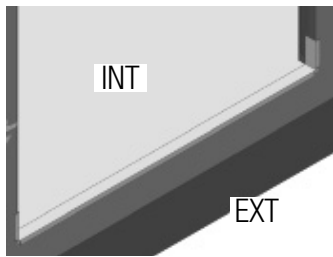

FIG. 6

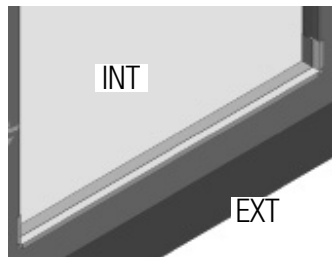

FIG. 7

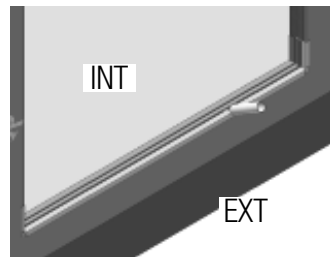

FIG. 8

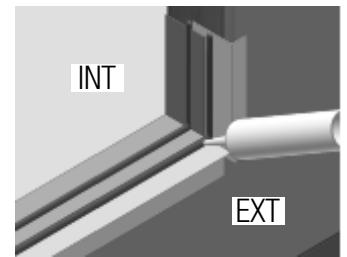

FIG. 9

Step 5: Frame Assembly

- A) Remove all packaging material (blocks, pads, protectors, stretch wrap)
- B) Inspect and verify the following:
 - a. The door is the correct size and specification.
 - b. The unit is free from any damage or defects.
- C) Contact the nearest Windsor distributor if there are any problems with Step B above.
- D) Attach one gasket to each end of sill before attaching jamb. Attach the jambs to the sill with the 2-1/2" x #8 screws provided. (Fig. 10)
- E) For 6-1/2" sill – trim excess gasket with utility knife.
- F) Apply 100% silicone sealant to the end of the head track assembly, attach the jambs to the head with the 2-1/2" x #8 screws provided. (Fig. 11)

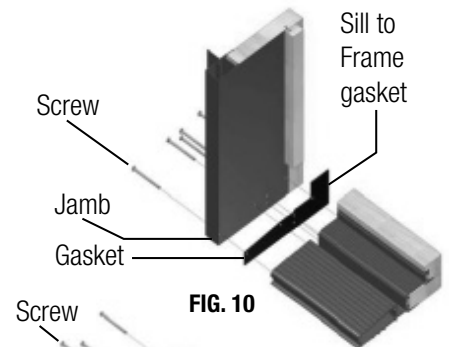

FIG. 10

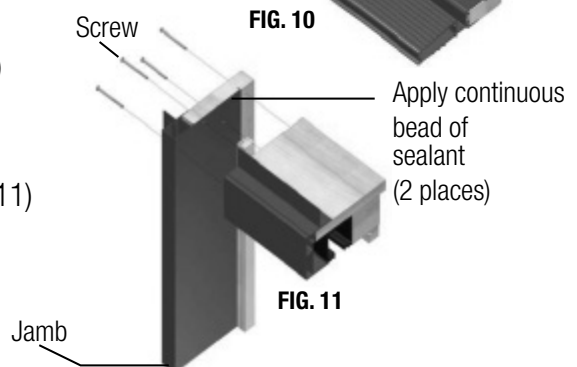

FIG. 11

Step 6: Frame Installation

- A) Apply sealant:
 - a. Cut an "L" shaped piece of flashing tape and apply over the nailing fin open corner between the jamb and head.

- b. Apply a 1/4" diameter bead of 100% silicone sealant along the backside of the nailing flange.
 - c. Bead must run continuously around both sides and across the head.
 - d. Apply flashing tape over nailing fin corner joint. (Fig. 12)
- B) Set the frame in the opening. Mark the location where the wall pivot cup will contact the rough opening. Drill a 1" hole approximately 3/4" deep into the rough opening to accommodate the cup plus some adjustment allowance.
- C) Set the frame into the rough opening. Center the frame in the opening, making sure there are equal gaps on both sides of the frame.
- D) Temporarily tack the frame into place using 1-1/2" x #8 coated deck screw on one top corner of the nailing flange.
- E) Check the unit for square using diagonal measurements. Shim frame to ensure the unit is square. Check the unit for square. The difference between the diagonal measurements shall not exceed 3/16". (Fig. 13)
- F) Screw all four corners in place through the nailing flange using 1-1/2" x #8 coated deck screws.
- G) Make sure jambs, head and sills are straight. Additional shimming will be required.
- H) Shim jambs at each corner, at each well pivot and in line with each panel hinge elevation. Place enough shims so that there is no more than 24" between any two shims. See Fig. 14 for minimum shim placement.

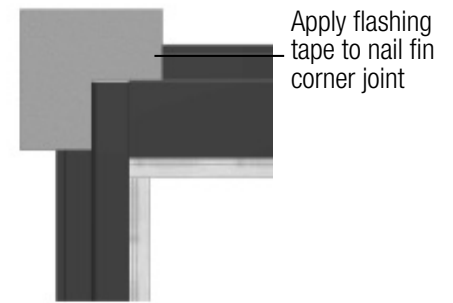

FIG. 12

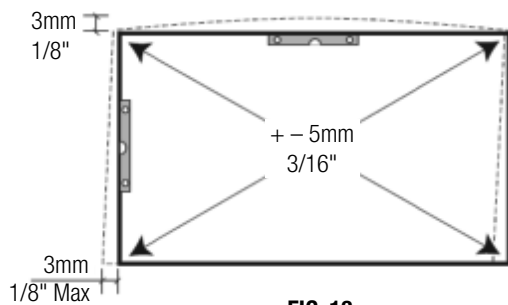
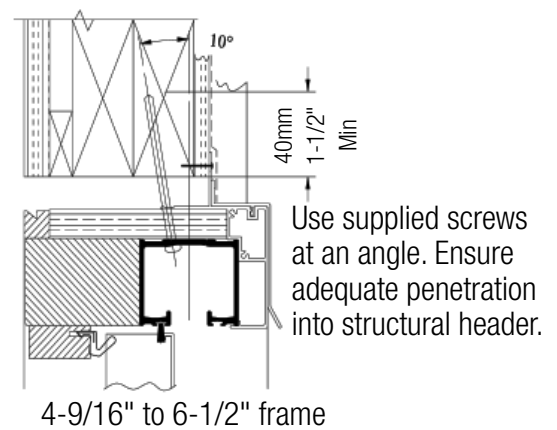
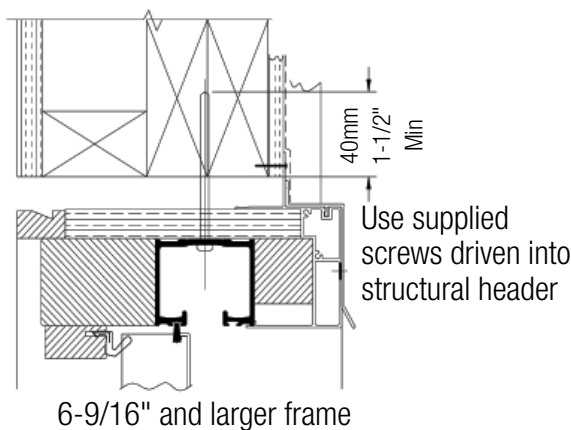

FIG. 13



FIG. 14

- I) Shim between the top track and header at each pre-drilled screw hole in the top track. Screw the top track to the structural header using the 3-1/2" x #10 screws provided. Place a screw in each of the screw holes provided. The screw holes are closer together near the ends of the track. NOTE: On doors with a 6-1/2" sill, the top track may be near the edge of the structural header; in this case the screw holes are angled to help guide the screws into the header. Screws MUST be driven into the header to ensure proper positioning and fastening of the frame. The 3-1/2" screws provided are only a suggested size. Ensure the screws penetrate at least 1-1/2" into the structural header that carries the weight of the door.



- J) Ensure that the sill and the top track are level and parallel. The top track cannot bow downward, but may bow upward up to 1/8". To screw the sill to the subfloor, drill a countersunk hole through the sill in line with the flush bolt cups and ensure the screw is well seated in the countersink.
- K) Finish screwing the door into place through the nailing flange with 1-1/2" x #8 coated deck screws, placing screws within 4" of each corner and no more than 8"-10" in between each screw. Only fiberglass batts are recommended for insulating above the door frame. Use of foam sealants may distort the frame.
- L) Clean inside of top track cavity and completely remove all metal shavings and other contamination. Failure to do so will embed debris into the wheels and track profile.

Step 7: Hang the Panels

- A) Refer to the hardware quantities and assembly order provided in the unit packing list. Note carrier locations and orientations.
- B) Insert the carriers and top pivot assemblies into the clean head track in the order shown on the packing list. Make sure carriers are installed in the correct orientation.
- C) Secure each top pivot assembly into the top track with the flat head screws provided.
- D) Install and secure each bottom pivot assembly into the sill track with the flat head screws provided.

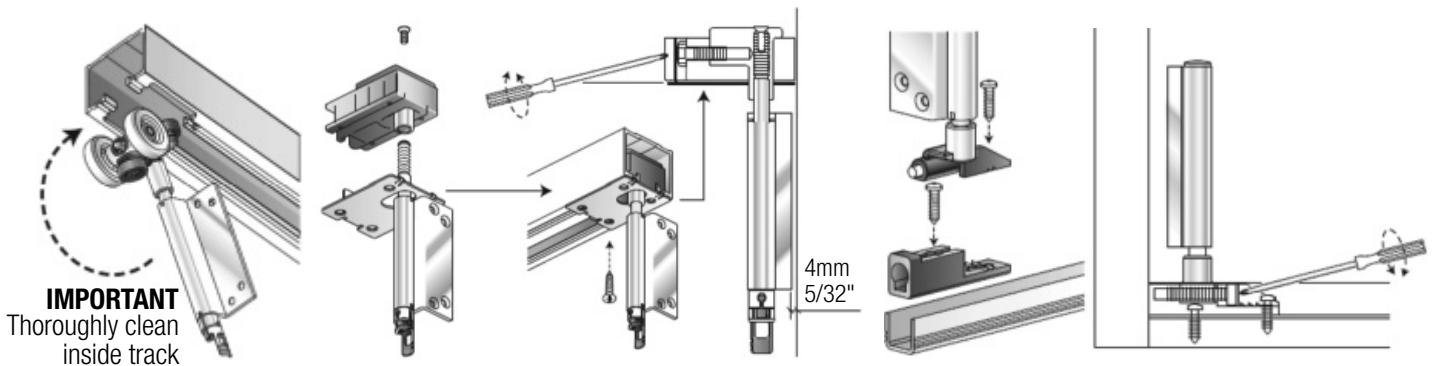

- E) Once more, thoroughly clean the extruded aluminum head track and remove any debris. Lubricate the track and the wheels with a small quantity of white petroleum jelly (Vaseline). This will improve smooth operation, and help to preserve the bearings and track. Check that the carriers move freely along the full length of the track.
- F) NOTE: For ease of installation, each panel has been numbered on the bottom of the panel. Panels are always numbered from left to right when viewed from the exterior. The recommended order of panel installation is shown in the packing list and may be different from the panel numbering.
- G) Set the door panel closest to the jamb in the open position (or 90 degrees to the opening) on supporting shims. The bottom edge of door panel should be level and at the sill height, or slightly above. Make sure the wall pivot is placed into the hole provided. Screw the top pivot hinge into the predrilled holes on the door. Screw bottom hinge into door. Adjust the top and bottom pivot so the panel is plumb.

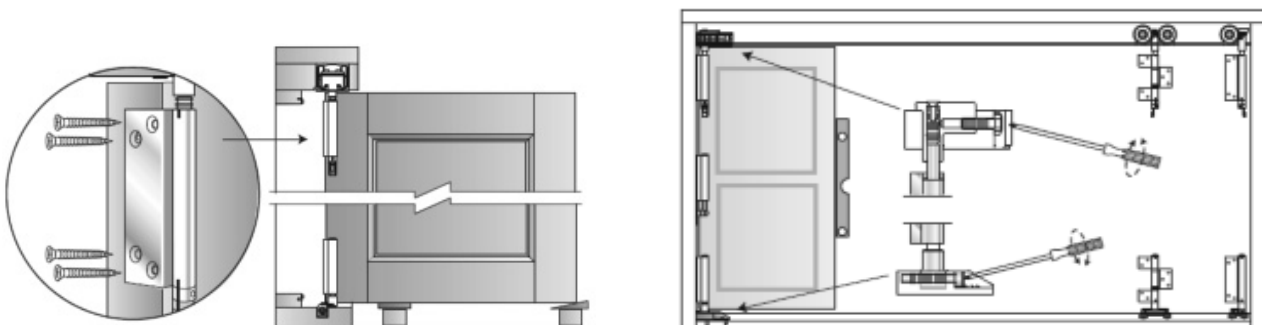

- H) Continue adding panels, working from the side jambs towards the middle, placing the hinge screws and carrier hinge screws into the predrilled holes.
- I) Open the door panels and adjust all the carriers vertically with a suitable screwdriver to set the top edges of all panels straight and flush.
- J) Test-operate all door panels. Inspect the gaps at the end panels while the doors are closed. If the gaps are uneven, open the doors and adjust the horizontal screw on the top and bottom pivots. Fine-tune and adjust until the doors operate smoothly, and the gaps are even and acceptable.
- K) Remove the carrier-shipping clip (yellow) from each carrier, and turn the carrier pin engaging the SureLock™. **IMPORTANT:** Check that all the SureLock clips are engaged, or door will quickly fall out of adjustment.

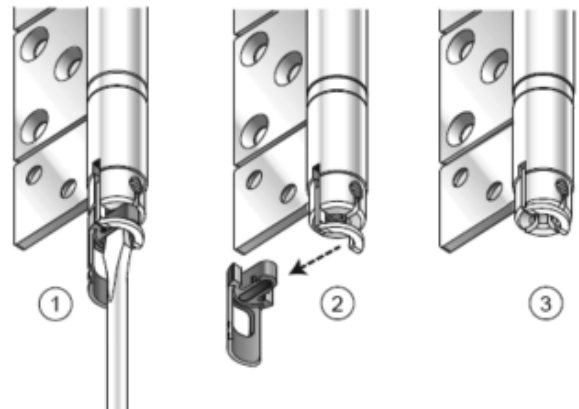
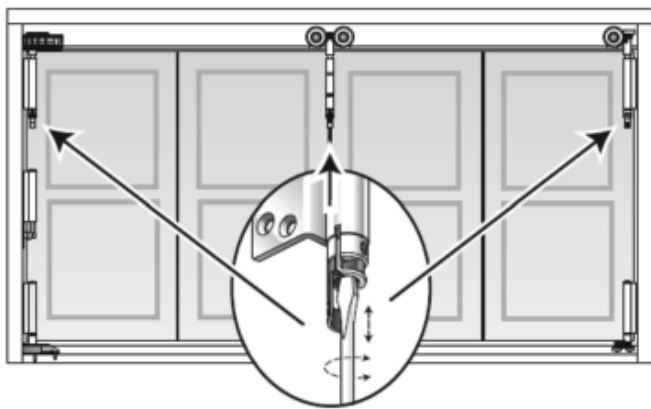
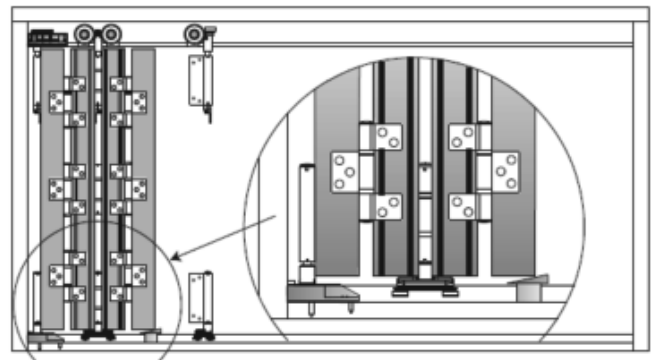

- L) Snap bottom pivot caps into place.
- M) The gasket has adhesive on both sides for sealing purposes.

Step 8: Install Head Drip Cap

- A) Apply a 1/4" continuous bead of 100% silicone sealant to the top of each joint where the jambs meet the head. (Fig. 15)
- B) Apply a 1/4" continuous bead of 100% silicone sealant to the backside of the drip cap nailing leg. Install the drip cap flashing across the top of the door. Secure it to the framing using galvanized roofing nails near the top of the vertical leg. (Fig.16)

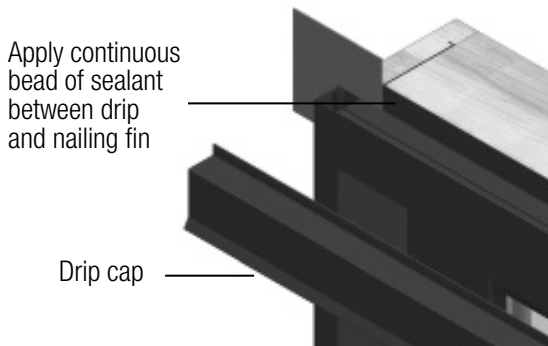

FIG. 15

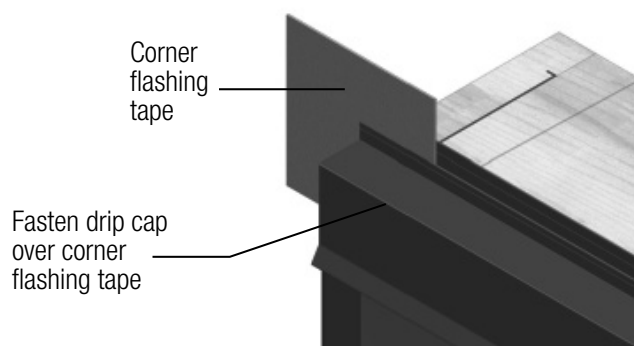

FIG. 16

Step 9: Complete Flashing

- A) Cut and apply side flashing. Side flashing should run from the bottom of the sill flashing to 8" above the rough opening. (Fig. 17)
- B) If non-adhesive flashing is used, make sure all staple holes are sealed with silicone.
- C) Cut and apply head flashing. The head flashing should be on top of the drip cap flashing. The head flashing should run slightly past the edge of the side flashing. (Fig. 18)
- D) Flip down the top flap of the WRB.
- E) Tape the cut seams of the WRB. (Fig. 19)

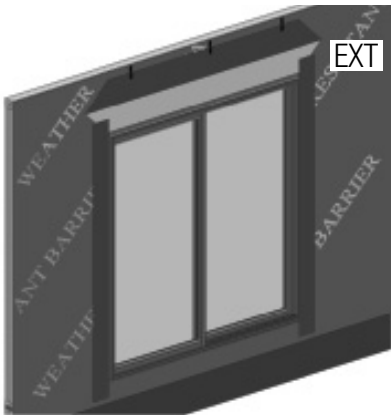

FIG. 17

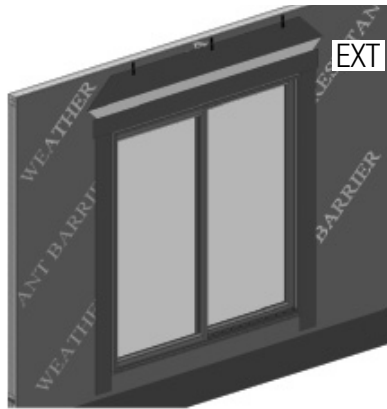

FIG. 18

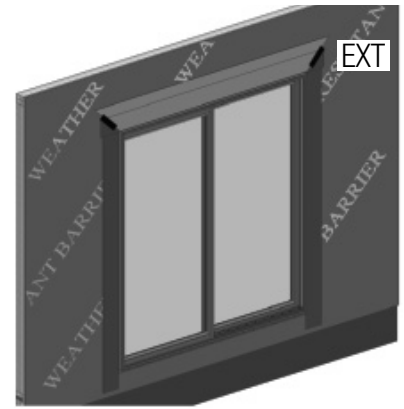

FIG. 19

Step 10: Seal the Exterior

- A) **WARNING:** Maintain a minimum of 1/4" between the window frame and any trim, siding or masonry. Failure to do so will forfeit all warranties (written or implied). Windsor Windows & Doors will not be held responsible for any claims or damages resulting from failure to follow these instructions.
- B) After siding or wall exterior is complete, apply backer rod and sealant between the door frame and siding material on both sides and sill. Make sure to use 100% silicone sealant. (Fig 20)
- C) Apply a continuous bead of sealant at the joint between the side jambs and the sill, and between the side jambs and the top jamb.

Step 11: Complete the Interior

- A) Remove all labels or shipping materials.
- B) Various hardware adjustments may be required after installation. See the Care and use guide located at www.windsorwindows.com for further details.
- C) Insulate between the door frame and the rough opening using minimally expanding window and door spray foam insulation. Use caution to not overfill the gap causing the jambs to bow. It is not recommended to apply trim to the unit until the foam has cured to allow the excess to escape. (Fig. 20 & 21)

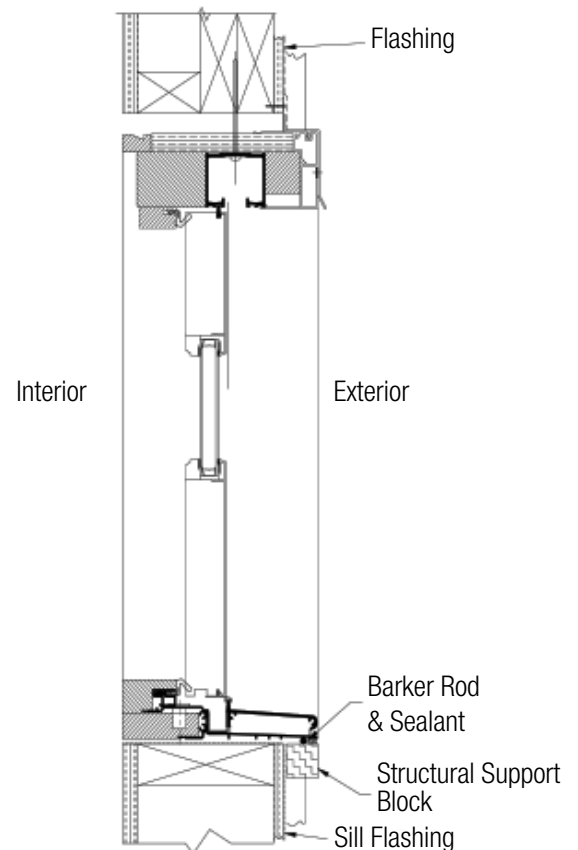

FIG. 20

- D) Operate door unit to ensure proper operation. The panel will not operate correctly if the door is out of square, over-shimmed or over-insulated.
- E) Properly finish all wood/cellular PVC interior and exterior components within 60 days of installation. See the Care and Use Guide located at www.windsorwindows.com for further details pertaining to finishing Pinnacle primed and Legend products.
- F) **IMPORTANT:** Do not stain or paint any hardware or vinyl components.
- G) Apply the handle set as appropriate per the manufacturer's recommendations. Complete final adjustments as necessary.
- H) Sliding and swinging doors are to remain closed and locked during construction to prevent site conditions from damaging and/or warping panels and frames. Allow 10-12 weeks from project completion for building temperature and humidity levels to stabilize and door panels to acclimate.

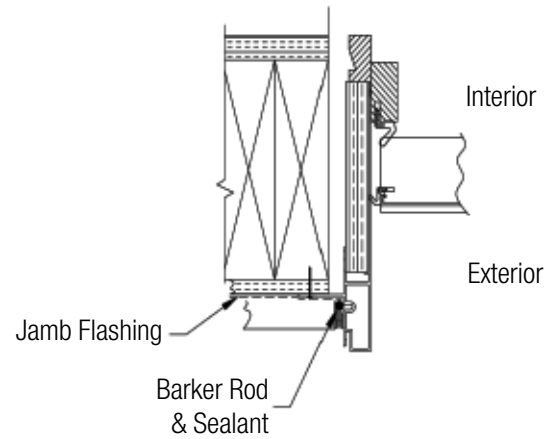

FIG. 21

CAUTION! READ BELOW BEFORE PAINTING

When painting cellular PVC products with darker paint colors (L values of 56 or below) UV irradiance can generate high localized temperatures in the product.

WARNING – Painting of any cellular PVC surface with a paint color darker than L value of 56 (where black = 0 and white = 100) will forfeit the product warranty.

If you should, despite the above warning, choose to use darker colors for cellular PVC paint, a paint specifically designed for these applications MUST be used. Contact the paint manufacturer to verify the paint's reflective properties and the suitability for painting cellular PVC.

If you should have any questions, from installation to adjustments of the Windsor products, please contact Windsor Windows directly at 1-800-218-6186. Also, if you choose, visit our website www.windsorwindows.com. In our **About Us/Contact Us Section**, you will find an easy to fill out form that will be forwarded electronically and your question(s) will be directed to one of our window specialists, who will contact you. While at our website please find our Windsor Care and Use Guide in the **Resources Section** to assist you in preserving the integrity and reliability of your Windsor products.

Care and Use

An inspection of your windows should be made annually. Visit the Windsor website (www.windsorwindows.com) or contact your local independent Windsor distributor for information on the care and use of your product. Ask for the Care and Use Guide, which contains information on finishing, cleaning, what to look for during yearly inspections, general maintenance tips, sash/panel adjustment, sash/panel removal, screen removal and information on condensation.